

OPENING PORTS FOR STEEL BOAT

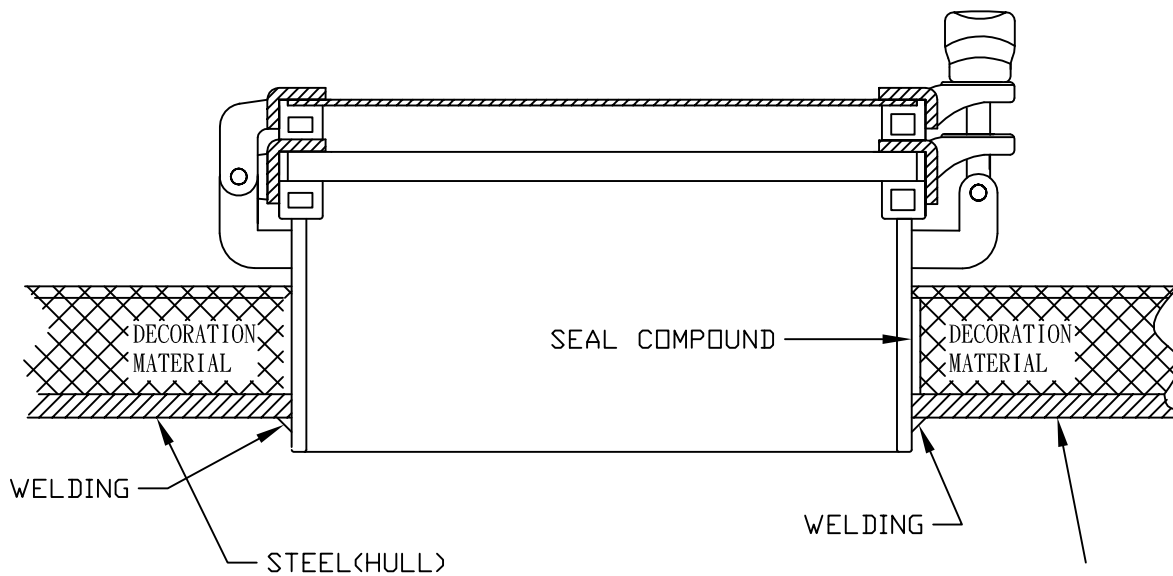

INSTALLATION:

1. DIG HOLE PER THE SPECIFICATION FOR CUT OUT SIZE OF PORTLIGHT IN HULL WALL.
2. TO PUT PORTLIGHT INTO HULL PROPERLY THEN WELDING.
3. FULL FILL SEAL COMPOUND BETWEEN HULL & DECORATION MATERIAL TO PREVENT WATER LEAKING.